



ARIES
MEDIUM DUTY \ UP TO 39,000 GVW
PARTS AND SERVICE MANUAL



Contact Information

For parts and service please contact:

Auto Truck
1200 N. Ellis St.
Bensenville, IL 60106

Phone: 630-860-5600
Toll free: 1-877-284-4440
+6Fax: 630-860-5631

e-mail: parts@autotruck.com

web address: www.autotruck.com

Please have the following information at hand before calling:

Vehicle make
Model
Year
Unit number

Table of Contents

Operation	4
Alignment and Adjustment	5
Lubrication and Maintenance	8
Troubleshooting	9
Brake System Schematic	10
Shunt System Schematic	11
Parts Diagrams	12

Operation

Safety and Tips for Safe Operation on Road

- Before road travel always ensure the rail gear is fully raised and the locks are properly engaged. Make sure the steering lock is disengaged.
- The steering and braking characteristics of your vehicle will be different due to the rail gear. If you are driving the vehicle for the first time, familiarize yourself with the steering and braking by driving the vehicle in a safe place before taking the vehicle on the road.
- Be aware that your vehicle may have reduced ground clearance due to the rail gear.
- Approach and departure angles may be different due to the rail gear. This will affect the way you approach dips, ditches, inclines and other surface irregularities.
- Do not use the rail gear as a hitch for towing vehicles or dragging objects. Use the correct hitch points on the vehicle frame.

Safety and Tips for Safe Operation on Rail

- Traction is very limited while on rail. Acceleration and braking must be done smoothly. Pay attention to the speedometer, it will over speed if the road wheels are slipping on the rail. Traction is further reduced when the rail is wet or snow/ice covered.
- Max speed on rail is 25 MPH.
- Recommended speed through a crossing is 5 MPH.
 - Be aware that flange ways can fill with dirt and gravel and cause the rail wheel flange to move on top of the rail.
- Traveling through spring-rail frogs, spring switch or self-guarded frogs, require you to **STOP** before moving through.
 - If possible, someone should remain on the ground to guard against derailment and direct the track car operator through the spring side of the frog.
- Recommended speed in reverse is 10 MPH Max. Be aware of engine temperature while in reverse - overheating may result from decreased airflow through the radiator.
- Do not exceed the speed limits imposed by the railroad for your type of vehicle. Remember that the recommended maximum speed is for first class track in good condition. Actual track conditions will determine the safe operating speed, which in many cases will be lower than the maximum speed.
- Ensure that all necessary vehicle warning lights, strobe lights, flags and other required safety items are working and in place before operating on track.
- When on rail do not operate cranes, aerial baskets, grab booms or other similar equipment unless their stabilizer legs are properly engaged with the ground. Severe damage to the rail gear or the vehicle frame will result.
- Sound horn when approaching road crossings.
- Do not steer on track...steering lock should must be engaged.
- Watch for individuals on or around the track.
- Check your tire pressure - improperly inflated tires will seriously affect the load carrying capacity and directional control of the vehicle.
- Watch for debris on the track. Even small obstructions could cause a derailment.
- Watch for overhead wires above or alongside the track.
- Watch for obstructions alongside the track. If in doubt do not proceed until you have checked clearances on your vehicle.

Placement of Vehicle on Rail

1. Find a suitable road crossing to position the vehicle on rail. If necessary, set up cautionary devices to ensure safety.
2. Position the vehicle with the road wheel tires on the rails, and the rail wheel flanges positioned centrally above the railhead. Backing into position is usually easier.
3. Put the vehicle's transmission in park or neutral. Set the parking brake.
4. Engage the PTO hydraulic pump or start the auxiliary hydraulic power source.
5. The rear will be placed on rail first.
 - a. Raise the rail gear up a bit to relieve the pressure on the lock hook.
 - b. Pull the T-handle for the lock to swing the hook out of the way.
 - c. Lower the rail gear into position on the rail.
 - d. Release the T-handle for the lock.
6. Check the alignment of the front rail wheels with the track - it might be necessary to adjust the position of the vehicle.
7. The front rail gear will now be lowered.
 - a. Raise the rail gear up a bit to relieve the pressure on the pin lock.
 - b. Rotate the **RED** lock handle forward to disengage front locks.
 - c. Lower the rail gear.
8. Engage the steering lock.
9. Drive the vehicle forward and backward a few yards to check vehicle's operation and brakes.
10. Vehicle is now ready for rail travel.

Removal of Vehicle from Rail

1. Find a suitable road crossing to remove the vehicle from the rail.
2. Put the vehicle's transmission in park or neutral. Set the parking brake.
3. Engage the PTO hydraulic pump or start the auxiliary hydraulic power source.
4. The front will be raised first.
 - a. Raise the rail gear into the road position.
 - b. Rotate the **RED** lock handle back towards the truck to engage the lock.
5. The rear will now be raised.
 - a. Raise the rail gear
 - b. The hook lock will automatically swing out of the way of the raising rail gear and swing into locking position.
6. Disengage the PTO hydraulic pump or auxiliary hydraulic power source.
7. Disengage the steering lock.
8. The vehicle is now ready to be driven on the road.

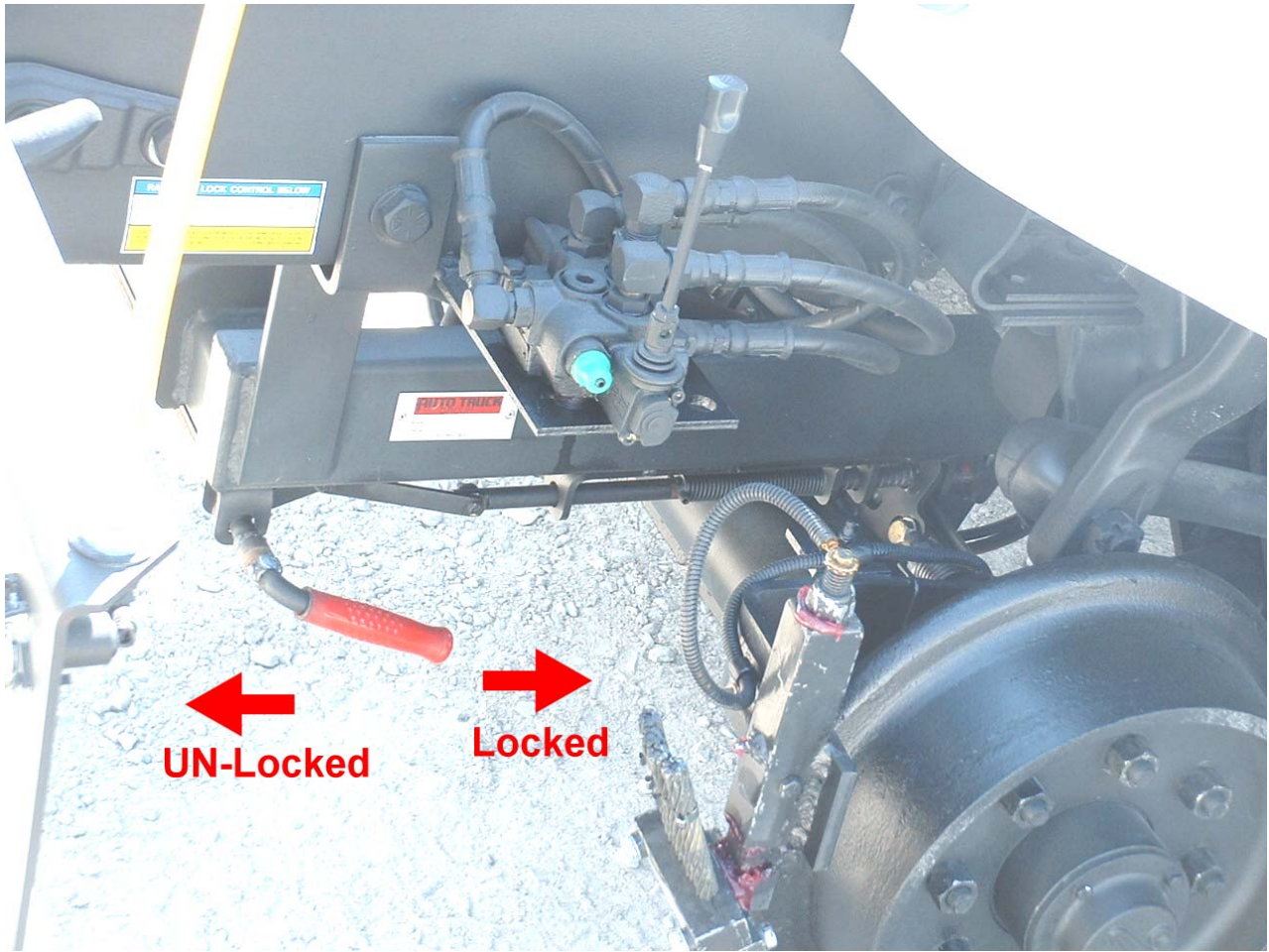

Front Rail Gear Lock Operation

Alignment and Adjustment

The alignment needs to be performed on a clean level solid surface. Position the vehicle on either 2x4s or a piece of steel channel so that all road wheels are approximately 1.5” higher than the surrounding floor level. Make sure that the 2x4s are long enough to support both the rail wheels and truck tires.

1. Set tire pressures to the maximum pressure as listed on the sidewall.
2. Set the position of the rear swing frame.
 - a. Loosen the stop bolt.
 - b. Fully extend the cylinder.
 - c. Adjust the swing frame stop bolts so they contact the swing frame plus ½ turn.
 - d. Tighten the lock nuts.
3. Suspension arms.
 - a. Suspension arms should be set to a horizontal position of 20° ±5°.
 - b. In the fully lowered position should raise the truck frame by 1.5” maximum (measured at a point no more than 12” from the rail wheel).
4. Adjust track gauge
 - a. Must be done before alignment.
 - b. Track gauge is adjusted by adjusting the position and/or number of washers on the stub axle.
 - c. Gauge is measured from the inside of the rail wheels. For both front and rear wheels 53” Min / 53.5”Max.
5. Using 2 standard railroad ties or equiv, transverse to the vehicle, run a string line down each side of the vehicle. String line should be positioned 6” from the rear wheel rim.
6. Measure the dimensions below, referring to the diagram on the following page. Make adjustments as needed to bring the rail gear into spec. Use the adjustment slots on the suspension frame and spacer washers on the rail wheels to bring the gear into alignment.
7. Tighten and torque the fasteners that were loosened during the alignment process.

Dimension Measurement	Max difference	Comment
A1 vs A2	1/16”	Truck frame or spring hanger to string line
B1 vs B2	1/16”	Rear wheel hub to string line
C1 vs C2	1/16” to 1/8” toe-in	Use 2’ straight edge across wheel to take measurement
D1 vs D2	1/16” to 1/8” toe-in	Use 2’ straight edge across wheel to take measurement
E1 vs E2	1/16” zero toe desired	Use 2’ straight edge across wheel to take measurement
F1 vs F2	1/16” zero toe desired	Use 2’ straight edge across wheel to take measurement
G1 vs G2	¼”	Center of rail wheel to string line
H1 vs H2	¼”	Center of rail wheel to string line

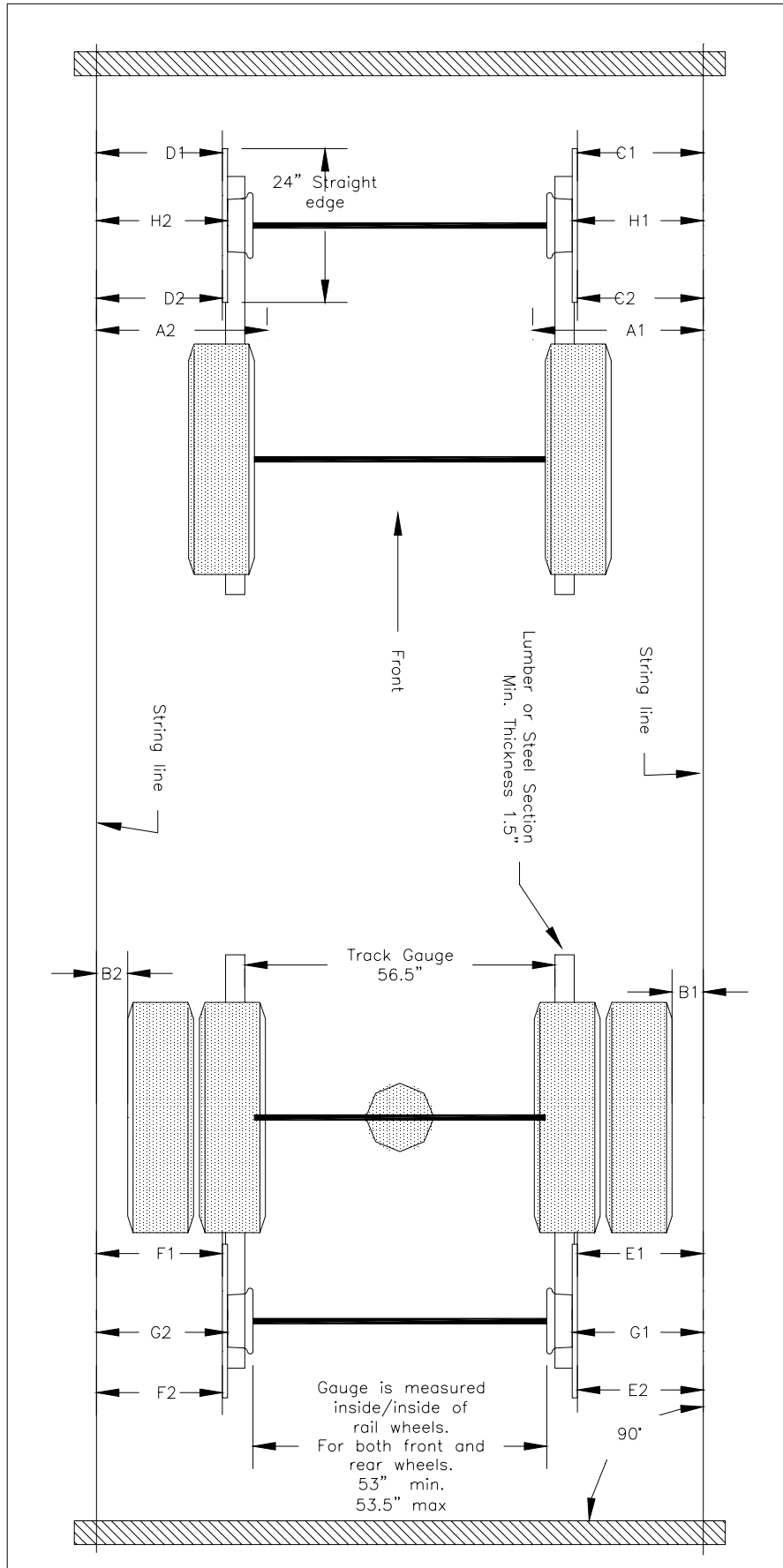

Rail Testing the Vehicle after Alignment

1. The vehicle must be tested on straight level track.
2. Apply a contrasting color of spray paint to the flanges and tread of the guide wheels.
3. Set the vehicle on rail and drive for a short distance at normal operating speed.
4. Stop the vehicle.
5. Look at the guide wheels. The paint should be worn evenly across all the wheels on a properly aligned vehicle.
6. Looking at the front wheels, if more paint is worn off the left wheel flange than the right the vehicle is said to be “flanging left”, the opposite condition is known as “flanging right”.
 - a. To correct a “flanging right” condition we want to add some toe-in to right wheel. That is to make C1 a bit greater than C2 referring to the alignment diagram. Loosen the suspension body to make this adjustment.
 - b. If the gear is “flanging left” we want to add some toe-in to the left wheel. That is to make D1 a bit greater than D2 referring to the alignment diagram. Loosen the suspension body to make this adjustment.
7. Repeat beginning at step #2.
8. If there are still alignment issues repeat the rail gear alignment.
9. If the issues are still present after the alignment, the vehicle frame and/or suspension may have problems. Check the rear vehicle wheels, looking to make sure the wheels are square to the truck frame. The rear end of the truck may have to be loosened and shifted back into alignment.

Lubrication and Maintenance

Daily

Check the rail gear for general appearance and damage.

Check the hydraulic fluid level. Add oil as required

Check for hydraulic oil leaks, kinked or damaged hydraulic hoses. Repair leaks and replace hoses as required.

Check that wheels rotate easily.

Check condition of rail wheels.

Weekly

Lubricate moving parts, cylinder clevis pins, main pivot pins, locking pins etc.

Monthly

Check grease zerks for damage and replace as necessary.

Grease all zerks.

12 Months or 9000 On-track Miles

Clean and repack rail wheel bearings.

Drain and refill hydraulic fluid.

Recommended Hydraulic Oils

Mobil AW32 or equivalent

Troubleshooting

Condition	Possible Cause
Hydraulic cylinder movement slow or uneven	Oil viscosity too high Low oil level Slow engine speed (if pump is driven from vehicle gearbox PTO) PTO not engaged Oil flow restricted to pump
Noisy pump, oil foaming, erratic cylinder movement	Air leak on inlet side of pump Worn pump Incorrect oil viscosity Oil restricted to pump Low oil level
Overheating	Incorrect oil viscosity Worn pump Restriction in hydraulic line Incorrect pressure relief valve setting
Rail guide wheels flanging to one side	Rail guide wheels out of alignment Vehicle or rail unit brakes partially applied Damaged pivot arm or rail wheel axle
Vehicle leaning to one side	Load not balanced, overloaded to one side Suspension body damaged Vehicle suspension damaged
Insufficient rail gear ground clearance when in the road position	Locks not properly engaged. Overloaded vehicle
Vehicle derails	Rail gear out of alignment Vehicle speed is excessive Track gauge incorrect Vehicle out of alignment Rail wheels worn or damaged Tire air pressure incorrect
Rail gear doesn't lower or raise	Lock pins or hook engaged Vehicle overloaded Hydraulic cylinder rod bent Insufficient lubrication on pivot pin Incorrect pressure relief valve setting Low oil level

HYDRAULIC BRAKE WIRING DIAGRAM

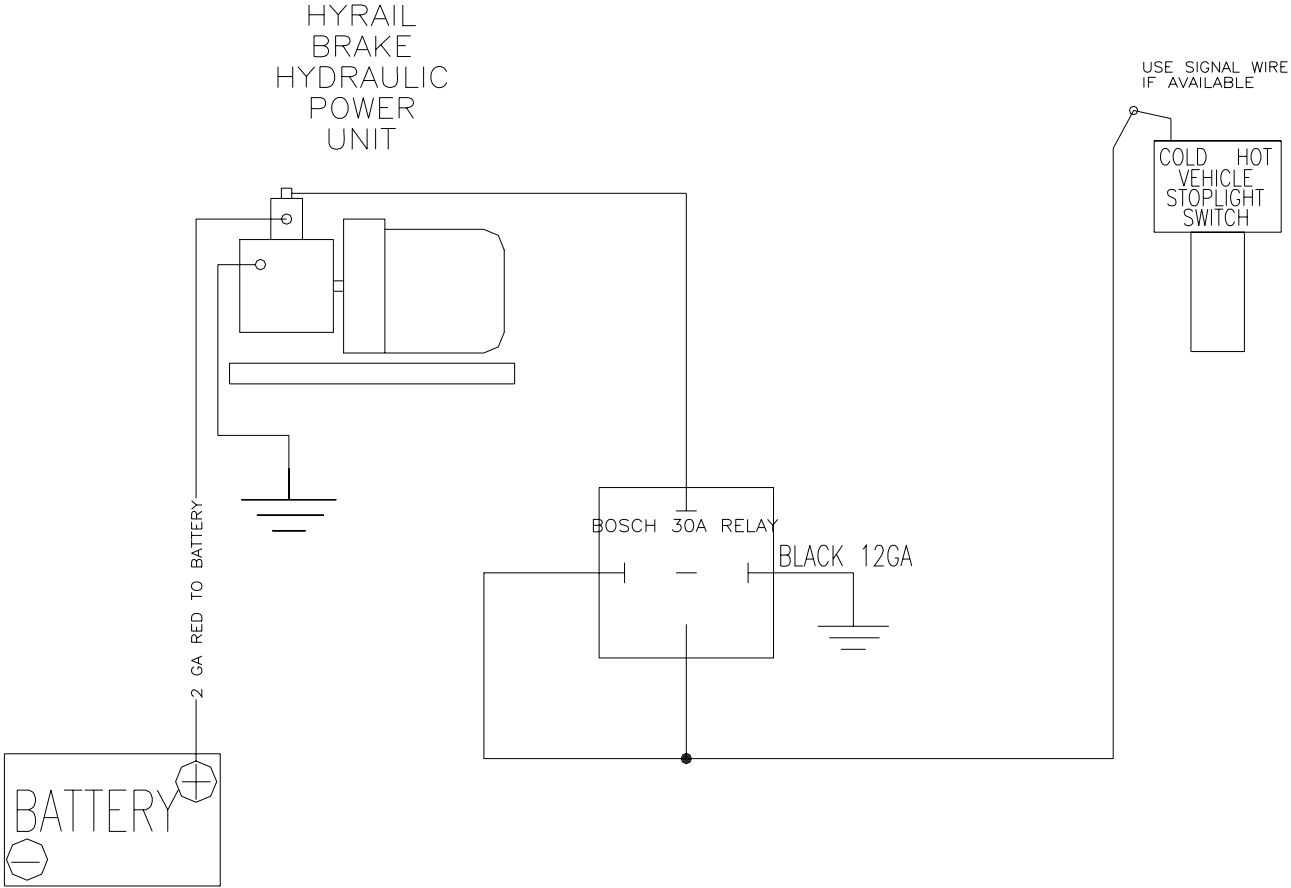

SHUNT WIRING DIAGRAM (OPTIONAL)

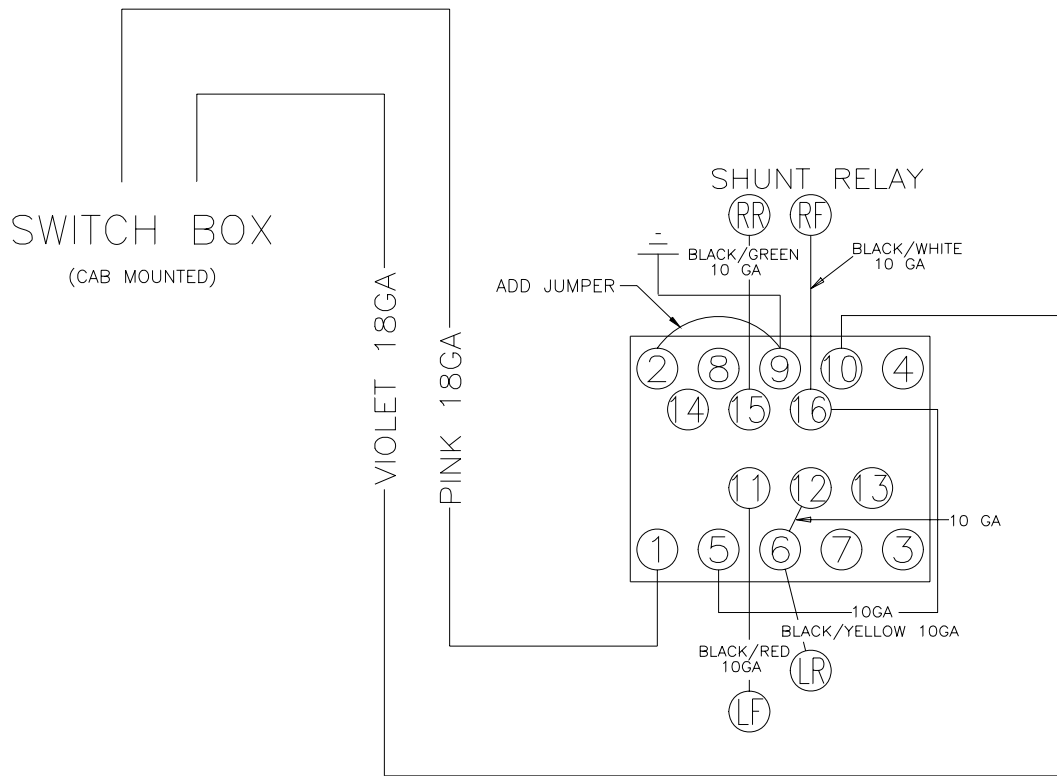

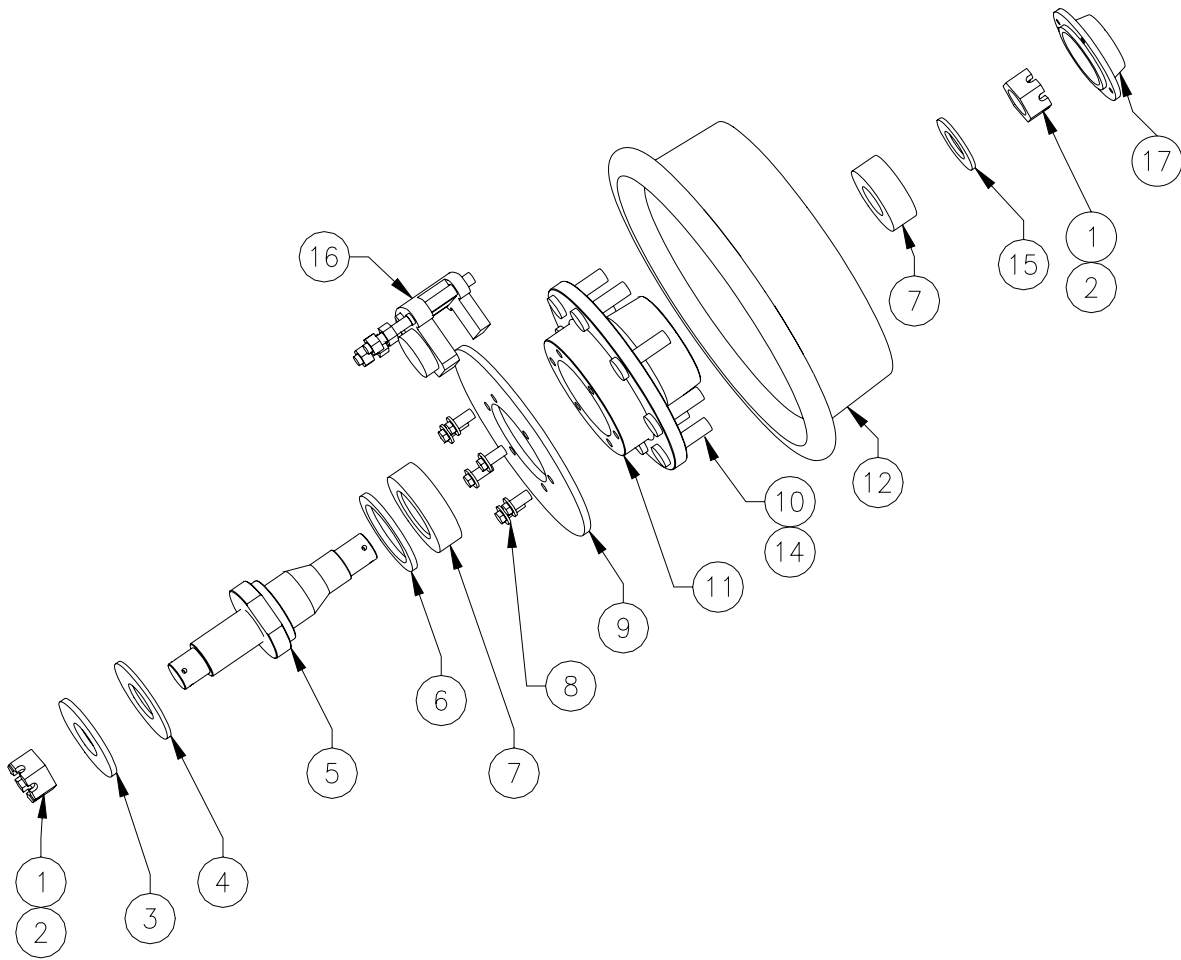

COMMON BEARING ASSEMBLY

ITEM	PART NUMBER	DESCRIPTION	QTY
1	95135	NUT; SPINDLE	8
2	800262	COTTER PIN	8
3	95111-4	AXLE SPACER; 1/8" THICK; NO CHAMFER	4
4	95111-5	AXLE SPACER; 1/8" THICK; NO CHAMFER	4
4a	95111-6	AXLE SPACER; 3/16" THICK; CHAMFER	4
5	94077-6	STUB AXLE; 2 PIECE	4
6	19664	SEAL; DOUBLE LIP	4
7	95137	BEARING ROLLER TAPERED	8
8	M10X25	SCREW CAP; M10 X 25mm	6
8a	WLM10M21	LOCK WASHER; M10	6
9	95014	ROTOR; DISC; FOR 12" WHEEL	4
10	610281	STUD; WHEEL;	24
11	94189	HUB	4
12	94236-4	WHEEL; RAIL; 12"; 8 HOLE PATTERN	4
14	611051	NUT; WHEEL	24
15	95136	WASHER; SPINDLE	4
16	95126	BRAKE CALIPER	2
16a	95012	SLIDE CALIPER	4
17	95123	HUBCAP	4
17a	95123G	GASKET HUBCAP	4

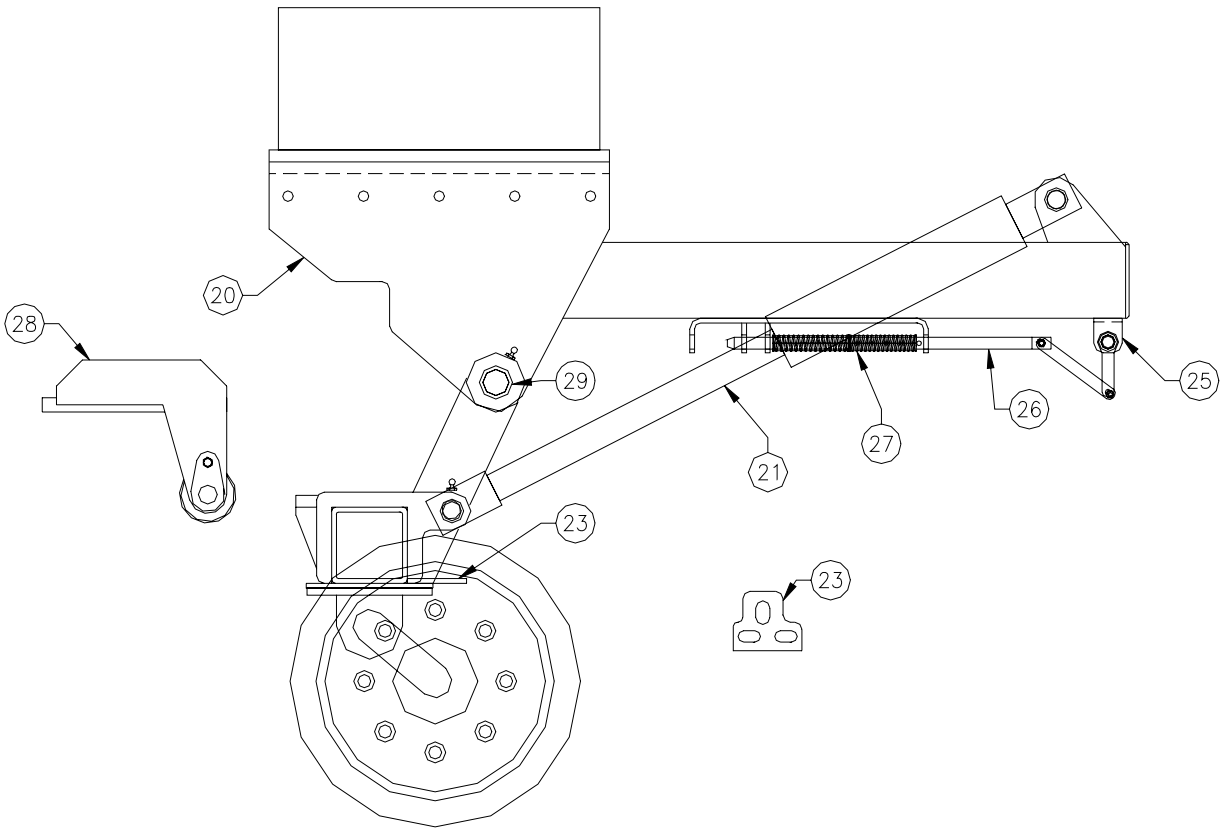

Side View of Front Attachment

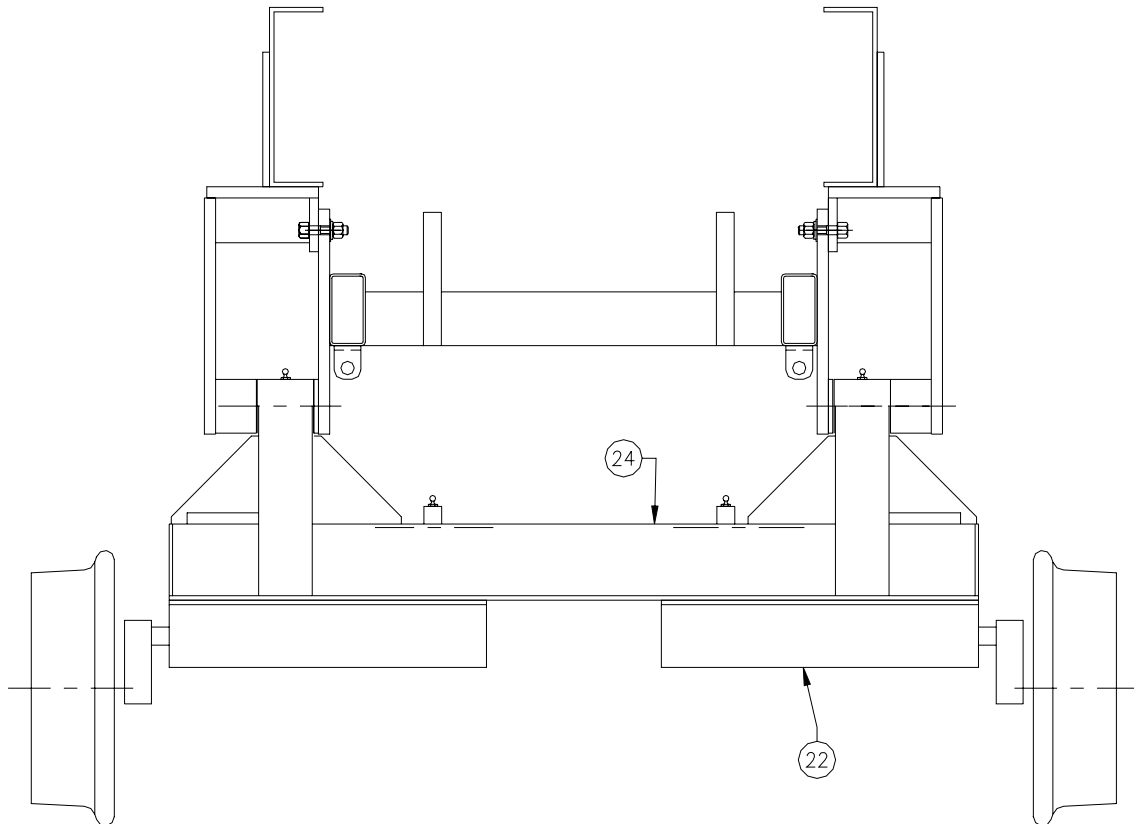

Front View of Front Attachment

ITEM	PART NUMBER	DESCRIPTION	QTY
20	1168-1	FRAME; FIXED; FITS NAVISTAR 4944	1
	1165-1	FRAME; FIXED; FITS NAVISTAR 4900	1
	2168BDF	FRAME; FIXED; FITS STERLING 7501	1
	1167-1	FRAME; FIXED; FITS C7 AND FREIGHTLINER FL70 AND HD7500	1
21	BMC2512	HYDRAULIC CYLINER	1
22	FS50NSA	SUSPENSION BODY	1 PR.
23	02054VBF	LOCK PLATE	2
24	1164-2	FRAME; SWINGING; FITS ALL	1
25	02054ABF	LOCK ASSEMBLY; FITS NAVISTAR 4900	1
	02054YBF	LOCK ASSEMBLY; FITS NAVISTAR 4944	1
	02168JDF	LOCK ASSEMBLY; FITS STERLING 7501	1
	02054KBF	LOCK ASSEMBLY; FITS FREIGHTLINER FL70 AND HD7500 AND C7	1
26	02054BBF	ROD; LOCKING	1
27	11982	SPRING; COMPRESSION	2
28	1164-31	ROLLER ASSEMBLY; RIGHT HAND; FITS FL70 AND FL80	1
	1164-41	ROLLER ASSEMBLY; LEFT HAND; FITS FL70 AND FL80	1
	1164-3	ROLLER ASSEMBLY; RIGHT HAND; FITS ALL OTHERS	1
	1164-4	ROLLER ASSEMBLY; LEFT HAND; FITS ALL OTHERS	1
29	116420	PIVOT PIN	2
30			

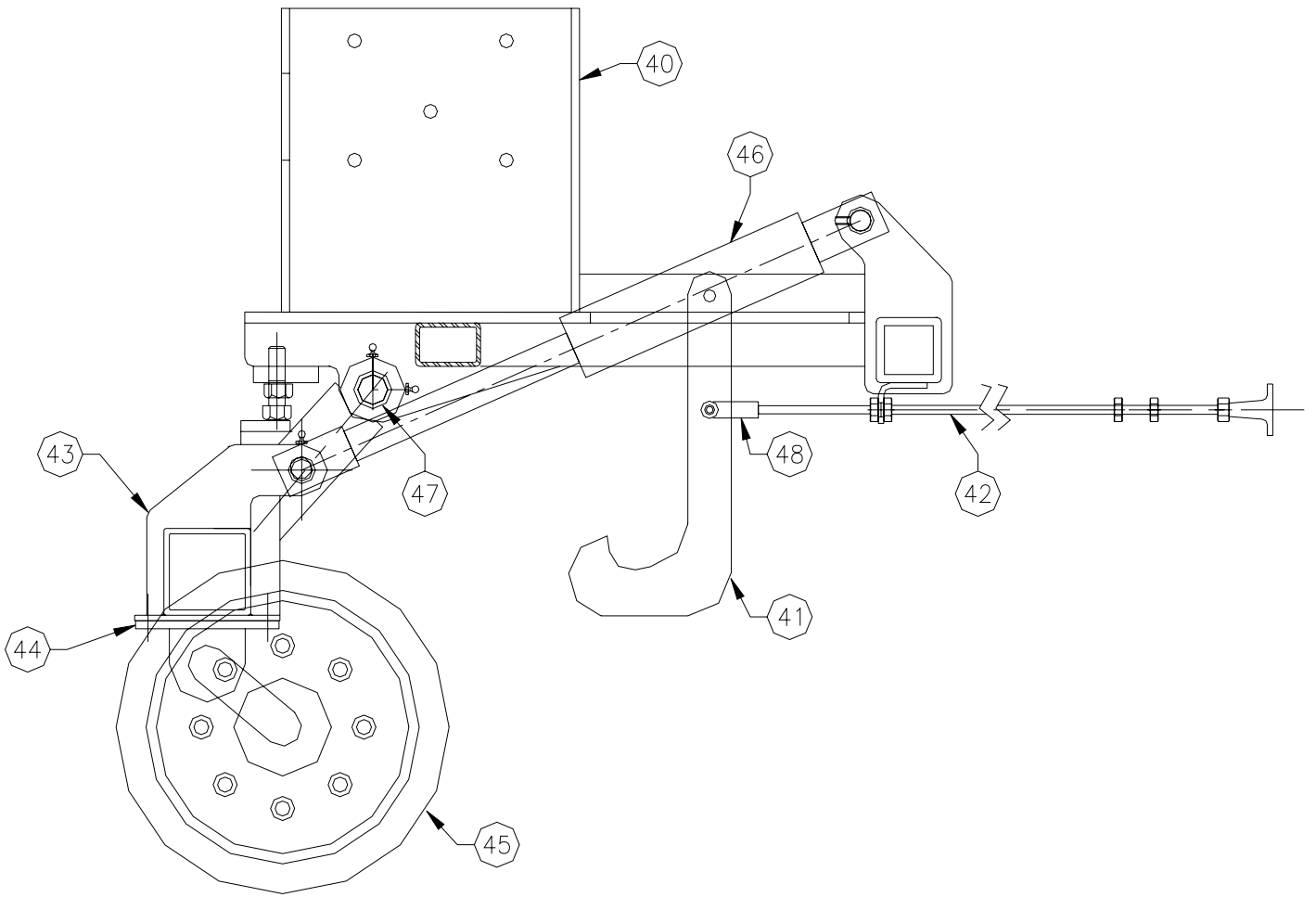

SIDE VIEW OF REAR ATTACHMENT

ITEM	PART NUMBER	DESCRIPTION	QTY
40	1163-2	FIXED FRAME	1
41	02184ADF	LOCK HOOK	1
42	XF100043270096	LOCKING CABLE 8'	1
43	1163-1	SWING FRAME	1
44	FS27NSA	SUSPENSION BODY	2
45	94236-4	WHEEL; RAIL; 12"; 8-HOLE	2
46	BMC2508H22	CYLINDER; HYDRAULIC	2
47	116328	PIVOT PIN	2
48	280204	CLEVIS	1

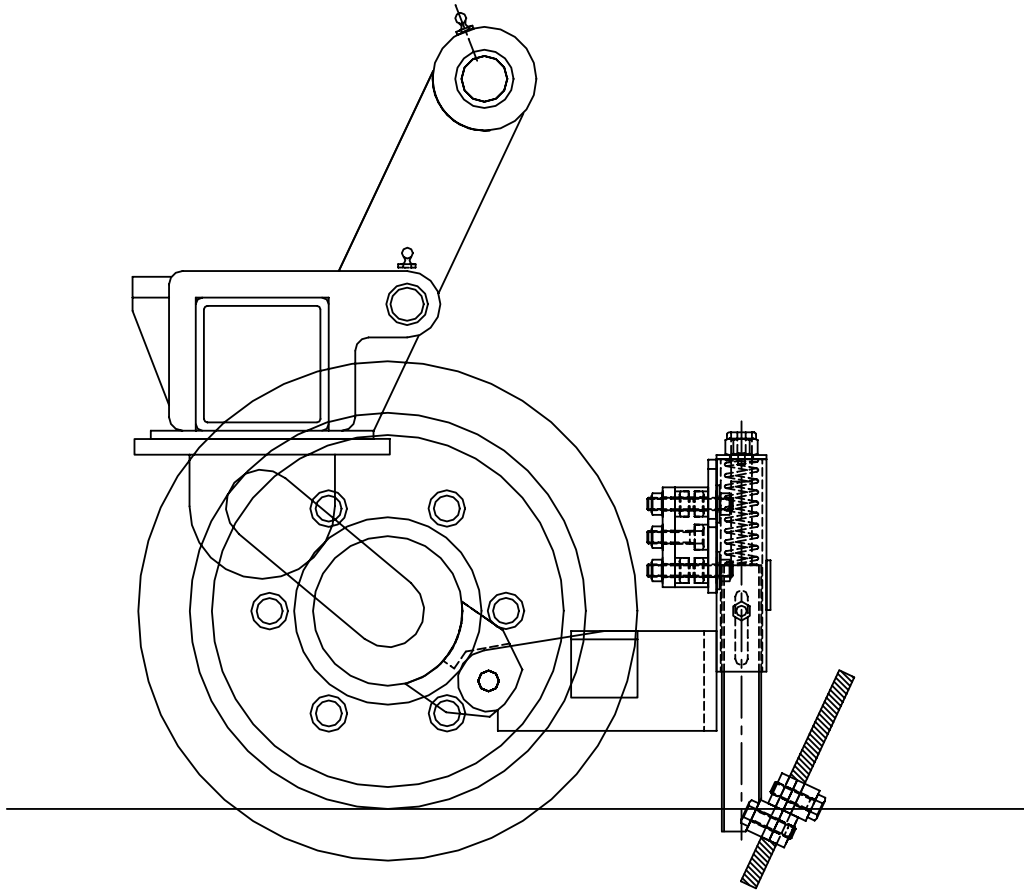

SIDE VIEW OF FREIGHTLINER SHUNT BRACKET

ITEM	PART NUMBER	DESCRIPTION	QTY
1	02087GBF	FREIGHTLINER DRIVERS SIDE SHUNT BRACKET ASSEMBLY; FLIP-UP	1

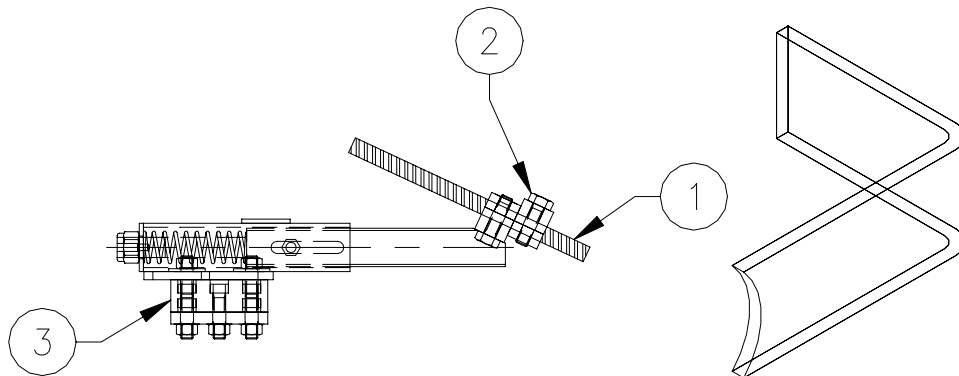

SIDE VIEW OF SHUNT and SHUNT BRACKET

ITEM	PART NUMBER	DESCRIPTION	QTY
1	WR1/2X8	SHUNT WIRE CABLE SOLD EACH	16
2	182501-11	PAIR OF WIRE BLOCKS; ONE THREADED AND ONE NOT	4
3	182501-10	PLASTIC INSULATOR BLOCK	1
4	95153F	PAIR OF SHUNT BRACKETS	2

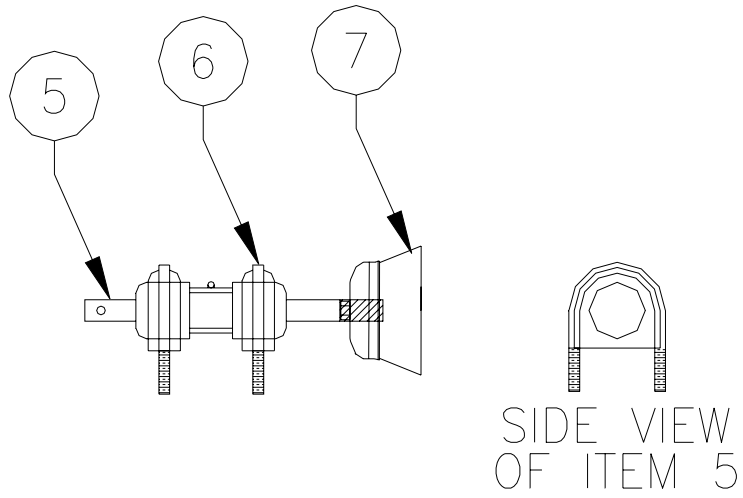

CUP BRUSH STYLE SHUNT

5	01589CDF	CUP BRUSH SHUNT	1
6	UB1PA	CLAMP AND INSULATOR	2
7	3ACO8	CUP BRUSH	1
8	01589BBF	FRONT BRACKET; CUP BRUSH SHUNT/SWEEP	2
9	01589CBF	REAR BRACKET; CUP BRUSH SHUNT	1

NOTE: QTYS LISTED ABOVE ARE PER SHUNT.

Check grease zerks for damage and replace as necessary.

Grease all zerks.

FASTENER TORQUES – GRADE 8 “WET”

Note: Wet is defined as any lubricant or plating present on either fastener or part to which it is attached.

<u>Fastener Size</u>		<u>Torque (ft-lbs.)</u>
Fraction	Decimal	
1/4 - 20	.250 - 20	10
1/4 - 28	.250 - 28	10
5/16 - 18	.313 - 18	20
5/16 - 24	.313 - 24	20
3/8 - 16	.375 - 16	30
3/8 - 24	.375 - 24	30
7/16 - 14	.438 - 14	50
7/16 - 20	.438 - 20	60
1/2 - 13	.500 - 13	80
1/2 - 20	.500 - 20	90
9/16 - 12	.563 - 12	110
9/16 - 18	.563 - 18	130
5/8 - 11	.625 - 11	160
5/8 - 18	.625 - 18	180
3/4 - 10	.750 - 10	280
3/4 - 16	.750 - 16	310
7/8 - 9	.875 - 9	450
7/8 - 14	.875 - 14	500
1 - 8	1.00 - 8	680
1 - 12	1.00 - 12	750
1 - 14	1.00 - 14	760

Note:

All critical mounting hardware using Grade 8 fasteners will be tightened to the proper torque specification as per the torque sheet unless the Body Manufacturer or the component supplier states otherwise.